

Operating Manual



Introduction

A proportional-integral-derivative controller (PID controller or three term controller) is a control loop feedback mechanism widely used in industrial control systems and a variety of other applications requiring continuously modulated control. A PID controller continuously calculates an error value as the difference between a desired setpoint (SV) and a measured process variable (PV) and applies a correction based on proportional, integral, and derivative terms (denoted P, I, and D respectively) which give the controller its name.

PT230-T/PT230-K is a single set point PID controller. It is available in both touch & keypad versions. Customized iconic display interprets status easily.

Caution for your safety

WIRING: The probe and its corresponding wires should never be installed in a conduit next to control or power supply lines. The electrical wiring should be done as shown in the diagram. The power supply circuit should be connected to a protection switch. The terminals admit wires of upto 2.5sq mm.

WARNING: Improper wiring may cause irreparable damage and personal injury. Kindly ensure that wiring is done by qualified personnel only.

Maintenance: Cleaning: Clean the surface of the controller with a soft moist cloth. Do not use abrasive detergents, petrol, alcohol or solvents.

Notice: The information in this document is subject to change in order to improve reliability, design or function without prior notice and does not represent a commitment on the part of the company. In no event will the company be liable for direct, indirect, special, incidental or consequential damage arising out of the use or inability to use the product or documentation, even if advised of the possibility of such damages. No part of this manual may be reproduced or transmitted in any form or by any means without the prior written permission of the company.

Controller: Controller should be installed in a place protected by vibration, water and corrosive gasses and where ambient temperature does not exceed the values specified in the technical data.

Probe : To give a correct reading, the probe must be installed in a place protected from thermal influences, which may affect the temperature to be controlled.

Dimensions

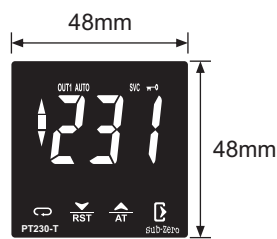

Panel Cutout

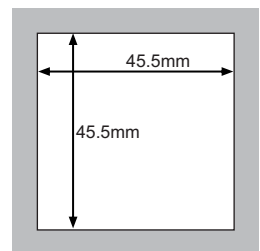

Product Mounting

Installation : Fixing and dimensions of panel models: To fix the unit, slide the fastener ① through the guides ② as per the position shown in the figure. Move the fastener in the direction of the arrow, pressing tab ③ it permits to move the fastener in the opposite direction of the arrow.

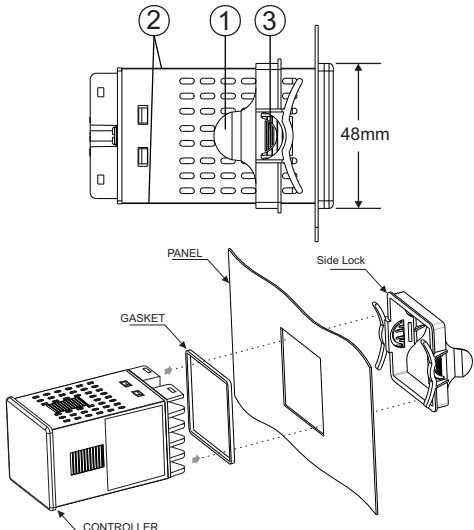

Connection Diagram (PT230T/K-W2C30)

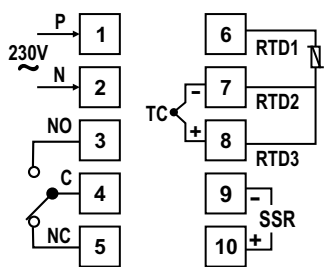

Connection Diagram (PT230T/K-W5C30)

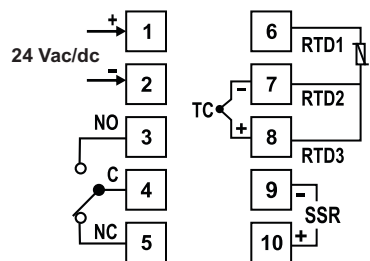

Index

Sr. No.	Para.	Description
		User Interface
		Technical Specification
		Input types & Input range
		Working
		Initial display when Power is ON
		Parameter setting mode
1	Set	Control set point.
		Level1 Parameter
2	InP	Sets the type of input sensor .
3	Inb	Sets input correction.
4	LSU	Sets the lower limit of PV input.
5	HSU	Sets the upper limit of PV input.
6	SuT	Set service time.
7	rSt	Factory reset parameter.
		Level2 Parameter
8	EnT	Sets control action for relay / SSR.
9	At	Runs auto tuning.
10	CT	Sets cycle time for PID action.
11	P	Sets proportional band.
12	I	Sets integration time.
13	d	Sets differential time.
14	HYS	Sets the hysteresis.
15	OUT	Sets Control output.
16	LoT	Lock keypad.
		LED Indications
		Pro-key (On Request)
		Error Messages
		Operating Messages (Pro-key Mode)
		Ordering Information

User Interface

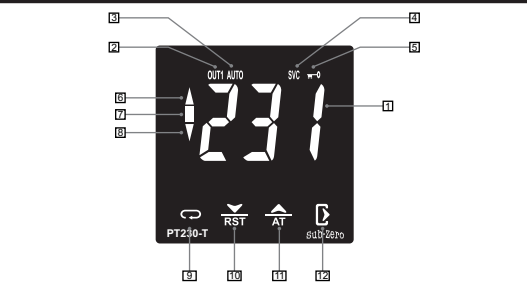

Sr. No.	Description
1	Process Value (PV) RUN mode : Displays current measured value. SETTING mode : Displays parameter.
2	OUT1 Turns ON while control output is ON.
3	AUTO Turns ON when auto tuning is in progress.
4	SVC Turns ON when service time elapsed.
5	Lock Turns ON when keypad is locked.
6	▲ Turns ON when the process value is > 5°C than set point.
7	■ Turns ON when the process value is within the 5°C range of the set point.
8	▼ Turns ON when the process value is < 5°C than set point.
9	Next key : Used to enters parameters level, moves to next parameters. Press & hold this key atleast 2 seconds to enter in set mode. Press & hold this key atleast 4 seconds to enter in Level1 Parameters. Press & hold this key atleast 6 seconds to enter in Level2 Parameters.
10	Down / Reset Key : Used in Program mode to decrement parameter value. Used to Reset SVC time.
11	Up / AT Key : Used in Program mode to increment parameter value. Touch & hold this key for 2 seconds to start or stop auto-tuning.
12	Exit Key : Press this key to save the setting value and to exit the programming mode.

Technical Specification

Housing : Polycarbonate Plastic
Dimensions : Frontal : 48 X 48mm, Depth : 78mm
Panel Cutout : 45.5 X 45.5mm
Mounting : Flush panel mounting with fasteners
Protection : IP65 Front
Connections : Terminal connectors.
 ≤ 2.5sq mm terminal only.
Display : 3 X 20mm 7 segment White display,
 7 Iconic LEDs for Indication
Data storage : Non-volatile flash memory
Operating temp. : 0°C to 60°C (non-condensing)
Operating humidity : 20% to 85% (non-condensing)
Storage temp : -25°C to 60°C (non-condensing)
Power input : 230 Vac ±15 % , 50-60Hz Standard.
 85 to 265 VAC/DC, 24 VAC/DC on request.
Control output : **Relay :** 10A, 230V AC (Resistive) or
 SSR (field selectable) : 10V DC, 30mA
Input Type : RTD : Pt100
 Thermocouple : J, K
Resolution : 0.1°C / 1°C for RTD (Pt100) input
 1°C for Thermocouple (J, K) input
Display Accuracy: RTD : 0.1% of F.S +/- 1°C
 Thermocouple : 0.3% of F.S
 (20 min of settling time for TC)
Sampling Period : 1 second

Input types & Input range

Input Type	Decimal Point	Display	Input Range (°C)
Thermocouple	J	J	-50 to 750°C
	K	K	-50 to 999°C
RTD	Pt 100	r.t.d	-99 to 400°C
		0.1	-9.9 to 99.9°C

Working

1. Auto tuning

The Auto-tuning function automatically computes and sets the proportional band (P), Integral time (I), Derivative time (D) as per process characteristics.

While Auto-tune is in progress "AUTO" led will turn ON. After Auto-tuning is complete the "AUTO" led will turn OFF.

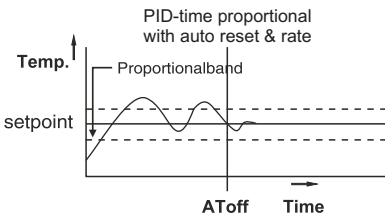

If auto-tuning is not complete after 3-4 cycles, it is suspected to fail. In this case, check the wiring & parameters such as the control action, input type etc. Carry out the auto-tuning again, if there is a change in setpoint or process parameters.

Note : In Auto Tuning running time, user can not change the parameter value.

2. ON/OFF control action (For reverse mode)

The relay is 'ON' up to the set temperature and cuts "OFF" above the set temperature . As the temperature of the system drops ,the relay is switched 'ON' at a temperature lower than the setpoint .

HYSTERESIS:

The difference between the temperature at which relay switches 'OFF' is the hysteresis or dead band.

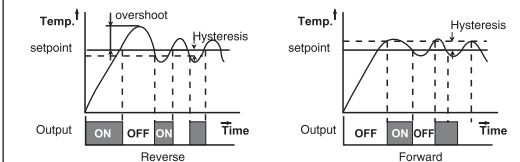

Initial Display when Power is ON

When power is supplied, whole display part will be flash for 3 sec, software revision will flash for 3 sec and then enters in to RUN mode.

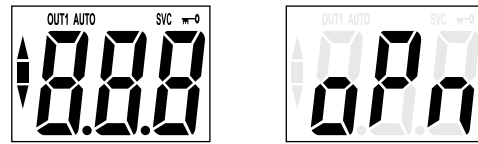

Parameter Setting Mode

SP Setting							
1	Set Parameter Function: To set control set point.						
Press & hold [] key for 2 seconds.							
Display will show Set . User can change Set value using UP/DOWN keys. Holding the key, will change the value at a faster rate. Press [] key to store the desired value & move on to the next parameter. Set value also can be stored by pressing Key []							
	<table border="1"> <thead> <tr><th>Min</th><th>Max</th><th>Fac.</th></tr> </thead> <tbody> <tr><td>LSU</td><td>HSU</td><td>0°C</td></tr> </tbody> </table>	Min	Max	Fac.	LSU	HSU	0°C
Min	Max	Fac.					
LSU	HSU	0°C					

LEVEL1 Parameter							
Press & hold [] key for 4 seconds to enter into Level1 parameter setting ([] will flash). When release the key, InP will flash. Press UP/DOWN keys to modify the set value and to go to the next parameter by pressing [] key. Press the [] key to save the set value and to come out of parameter setting after changing the set value.							
2	InP Parameter Function: Sets the type of input sensor .						
While changing the sensor type Set, Inb, LSU, HSU parameters of level1 will reset accordingly. For type of input sensor & range please refer "Input types & Input range" table.							
	<table border="1"> <thead> <tr><th>Min</th><th>Max</th><th>Fac.</th></tr> </thead> <tbody> <tr><td>J</td><td>r.t.i</td><td>J</td></tr> </tbody> </table>	Min	Max	Fac.	J	r.t.i	J
Min	Max	Fac.					
J	r.t.i	J					

3	Inb Parameter Function: Sets input correction.						
In time it may be possible that the display may be offset by a degree or so. To compensate for this error, user may need to add or minus the degrees required to achieve the correct temperature. Example : The temperature on the display is 28°C, whereas the actual temperature is 30°C. User will have to set the "Inb" parameter to 2°C, which means that once out of the programming mode, the temperature on display will be 30°C (28°C+2°C).							
	<table border="1"> <thead> <tr><th>Min</th><th>Max</th><th>Fac.</th></tr> </thead> <tbody> <tr><td>-20°C</td><td>20°C</td><td>0°C</td></tr> </tbody> </table>	Min	Max	Fac.	-20°C	20°C	0°C
Min	Max	Fac.					
-20°C	20°C	0°C					
4	LSU Parameter Function: Sets the lower limit of PV input.						

Sets the minimum limit for set point adjustment. It can be set from minimum specified range of selected sensor to HSV-1 value.

Once set at a particular value, this will not allow the set point to go below this value.

When changing the setting value and SV < LSU, SV will reset as LSU.

Sets the differential time of PID parameter.							
Term D is a best estimate of the future trend of the SV-PV error, based on its current rate of change. It is sometimes called "anticipatory control", as it is effectively seeking to reduce the effect of the SV-PV error by exerting a control influence generated by the rate of error change. The more rapid the change, the greater the controlling or dampening effect. Setting "0" will turn OFF differential.							
	<table border="1"> <thead> <tr><th>Min</th><th>Max</th><th>Fac.</th></tr> </thead> <tbody> <tr><td>0</td><td>999</td><td>30 sec</td></tr> </tbody> </table>	Min	Max	Fac.	0	999	30 sec
Min	Max	Fac.					
0	999	30 sec					
13	d Parameter Function: Sets differential time.						
Sets the differential time of PID parameter.							
Term D is a best estimate of the future trend of the SV-PV error, based on its current rate of change. It is sometimes called "anticipatory control", as it is effectively seeking to reduce the effect of the SV-PV error by exerting a control influence generated by the rate of error change. The more rapid the change, the greater the controlling or dampening effect. Setting "0" will turn OFF differential.							
	<table border="1"> <thead> <tr><th>Min</th><th>Max</th><th>Fac.</th></tr> </thead> <tbody> <tr><td>-50°C</td><td>HSU-1</td><td>-50°C</td></tr> </tbody> </table>	Min	Max	Fac.	-50°C	HSU-1	-50°C
Min	Max	Fac.					
-50°C	HSU-1	-50°C					

5	HSU Parameter Function: Sets the upper limit of PV input.						
Sets the maximum limit for set point adjustment. It can be set from LSV+1 value to maximum specified range of selected sensor. Once set at a particular value, this will not allow the setpoint to go above this value. When changing the setting value and SV > HSV, SV will reset as HSV.							
	<table border="1"> <thead> <tr><th>Min</th><th>Max</th><th>Fac.</th></tr> </thead> <tbody> <tr><td>LSU+1</td><td>750°C</td><td>750°C</td></tr> </tbody> </table>	Min	Max	Fac.	LSU+1	750°C	750°C
Min	Max	Fac.					
LSU+1	750°C	750°C					

6	SuT Parameter Function : To set service time.						
Service Time notify the machine user to carry out the machine maintenance settled at predefined time or to indicate that, the machine has worked for certain days. Example: If user set Service time to 10 days, then after 10 days of continuous service of machine, the SVC icon on controller will lit to indicate that service time has been elapsed or its time to service the machine							
	<table border="1"> <thead> <tr><th>Min</th><th>Max</th><th>Fac.</th></tr> </thead> <tbody> <tr><td>OFF</td><td>999 Day</td><td>OFF</td></tr> </tbody> </table>	Min	Max	Fac.	OFF	999 Day	OFF
Min	Max	Fac.					
OFF	999 Day	OFF					

7	rSt Parameter Function : To restore default settings of the controller.						
When Set to Yes all parameter are programmed to factory values. Useful to debug setting related problems.							
	<table border="1"> <thead> <tr><th>Min</th><th>Max</th><th>Fac.</th></tr> </thead> <tbody> <tr><td>no</td><td>YES</td><td>no</td></tr> </tbody> </table>	Min	Max	Fac.	no	YES	no
Min	Max	Fac.					
no	YES	no					

LEVEL2 Parameter	
Press & hold [] key for 6 seconds to enter into Level2 parameter setting ([] will flash). When release the key, EnT will flash. Press UP/DOWN keys to modify the set value and to go to the next parameter by pressing [] key. Press the [] key to save the set value and to come out of parameter setting after changing the set value.	

8	EnT Parameter Function: Sets control action for relay/SSR.						
This parameter used to set required control action for relay/SSR. OFF = No action rT = Reverse Fd = Forward Pid = PID							
	<table border="1"> <thead> <tr><th>Min</th><th>Max</th><th>Fac.</th></tr> </thead> <tbody> <tr><td>OFF</td><td>Pid</td><td>Pid</td></tr> </tbody> </table>	Min	Max	Fac.	OFF	Pid	Pid
Min	Max	Fac.					
OFF	Pid	Pid					

9	At Parameter Function: Runs auto tuning.						
This parameter used to set YES/NO to start and stop Auto-tuning. When Set as YES, the unit starts auto-tuning. After Completing no is automatically Set. During auto-tuning, the AUTO indicator continuously ON. This parameter will be prompted only if selected control action is PID in control parameters.							
	<table border="1"> <thead> <tr><th>Min</th><th>Max</th><th>Fac.</th></tr> </thead> <tbody> <tr><td>no</td><td>YES</td><td>no</td></tr> </tbody> </table>	Min	Max	Fac.	no	YES	no
Min	Max	Fac.					
no	YES	no					

10	CT Parameter Function: Sets cycle time for PID action.						
Cycle time also known as duty cycle, the total length of time for the controller to complete one ON/OFF cycle. Example : With a 20 second cycle time, an on time of 10 seconds and an OFF time of 10 seconds represents a 50 percent power output. The controller will cycle ON and OFF while within the proportional band.							
	<table border="1"> <thead> <tr><th>Min</th><th>Max</th><th>Fac.</th></tr> </thead> <tbody> <tr><td>1 sec</td><td>60 sec</td><td>3 sec</td></tr> </tbody> </table>	Min	Max	Fac.	1 sec	60 sec	3 sec
Min	Max	Fac.					
1 sec	60 sec	3 sec					

11	P Parameter Function: Sets proportional band.						
Sets the proportional band of PID parameter. Term P is proportional to the current value of the SV-PV error . Example : If the (SV-PV) error is large and positive, the control output will be proportionately large and positive and vice versa if error is negative.							
	<table border="1"> <thead> <tr><th>Min</th><th>Max</th><th>Fac.</th></tr> </thead> <tbody> <tr><td>0.1°C</td><td>99.9°C</td><td>10.0°C</td></tr> </tbody> </table>	Min	Max	Fac.	0.1°C	99.9°C	10.0°C
Min	Max	Fac.					
0.1°C	99.9°C	10.0°C					

12	I Parameter Function: Sets integration time.						
Sets the integration time of PID parameter. Term I accounts for past values of the SV-PV error and integrates them over time to produce the I term. Example : If there is a residual SV-PV error after the application of proportional control, the integral term seeks to eliminate the residual error by adding a control effect due to the historic cumulative value of the error. Setting "0" will turn OFF integration.							
	<table border="1"> <thead> <tr><th>Min</th><th>Max</th><th>Fac.</th></tr> </thead> <tbody> <tr><td>0</td><td>999</td><td>120 sec</td></tr> </tbody> </table>	Min	Max	Fac.	0	999	120 sec
Min	Max	Fac.					
0	999	120 sec					

13	d Parameter Function: Sets differential time.						
Sets the differential time of PID parameter.							
Term D is a best estimate of the future trend of the SV-PV error, based on its current rate of change. It is sometimes called "anticipatory control", as it is effectively seeking to reduce the effect of the SV-PV error by exerting a control influence generated by the rate of error change. The more rapid the change, the greater the controlling or dampening effect. Setting "0" will turn OFF differential.							
	<table border="1"> <thead> <tr><th>Min</th><th>Max</th><th>Fac.</th></tr> </thead> <tbody> <tr><td>0</td><td>999</td><td>30 sec</td></tr> </tbody> </table>	Min	Max	Fac.	0	999	30 sec
Min	Max	Fac.					
0	999	30 sec					

14 **Parameter** **Function:** Sets the hysteresis for ON-OFF action in $^{\circ}\text{C}$.

This parameter will be prompted only if selected control action is $r\bar{E}$ (reverse) or Fd (forward) in $\bar{L}n\bar{k}$ setting. It sets the deadband between ON & OFF switching of the output.

Example (For Fd control) : If the set point is set at 100°C and hysteresis is set at 2°C , then when the system reaches 100°C , the heater relay will go OFF. Since the hysteresis is 2°C , the heater relay will get ON (restart) at 102°C ($100^{\circ}\text{C} + 2^{\circ}\text{C}$).

Min	Max	Fac.
1°C	100°C	2°C

15 **Parameter** **Function:** Sets Control output.

This parameter is used to configure control out as, $SSR = \text{SSR}$, $rLY = \text{Relay}$

User has to set this parameter in accordance with the output used.

Min	Max	Fac.
SSR	rLY	rLY

16 **Parameter** **Function:** To lock keypad.

This parameter is used to lock the parameter so that tampering is not possible by by-standers ,

$n\alpha = \text{unlocked parameter.}$

Min	Max	Fac.
$n\alpha$	$Y\bar{E}\bar{S}$	$n\alpha$

$Y\bar{E}\bar{S} = \text{locked parameter.}$

When locked all parameters can only be viewed ,but can not be modified.

LED Indication

LED	Status	Description
OUT1	ON	Relay / SSR ON.
	OFF	Relay / SSR OFF.
AUTO	ON	Tuning is in progress.
	OFF	Tuning Stop.
SVC	ON	Service time elapsed.
	OFF	Service time is in progress or disabled.
Key	ON	Parameters are locked.
	OFF	Parameters are unlocked.
▲	ON	The process value is $> 5^{\circ}\text{C}$ than set point.
	ON	The process value is within the 5°C range of the set point.
▼	ON	The process value is $< 5^{\circ}\text{C}$ than set point.

Pro-Key (On Request)

To use Pro-key user must insert it prior to power ON. Insert the pro-key and power ON controller. When the display flashes for 5 seconds, touch the \bar{E} key for 1 second. Controller will enter into Pro-key mode and will display " $P_r\bar{K}$ ". Then touch either of the below given keys to use the Pro-key.

Functions of Pro-key and the keys to be used for are as given below:

Function	Keys to be Used
To upload the parameters from the controller	touch " \bar{E} " key
To download the parameters to the controller	touch " \bar{D} " key
To set and exit	touch " \bar{C} " key

If user tries to enter Pro-key mode without inserting the pro key or with wrong connection, no further function will be activated after displaying " \bar{E} " or " \bar{D} ". Controller will display " $P_r\bar{K}$ ". Then switch off controller and insert the pro key properly and try to enter Pro key mode.

User has to first Upload the parameters in the Subzero Validated Blank Pro-Key and then subsequently use it for downloading.

● Uploading mode

Press \bar{E} key to upload the parameters to Pro Key. Display will show " $u\bar{D}\bar{K}$ " once uploading is done. Press \bar{C} to exit display will show "----" and return to normal display.

● Downloading mode

Similarly connect Pro key to the controller . Press \bar{D} key to download all parameters from Pro key to the controller. Display will show " $d\bar{D}\bar{K}$ " once download is done. Once done press \bar{C} key to exit and display will flash and return to normal mode.



Error Messages

Message	Description
$o\bar{P}n$	Displays when input sensor is disconnected or sensor is not connected.
HHH	Flashes when measured value is higher than input range.
LLL	Flashes when measured value is lower than input range.

Operating Messages (Pro-key Mode)

Message	Description
$P_r\bar{K}$	Shows controller in Pro- key mode.
$u\bar{D}\bar{K}$	Parameter values are uploaded from controller to pro key. Press " \bar{C} " key to confirm uploading of parameter values from controller to the Pro key.
$d\bar{D}\bar{K}$	Parameter values are downloaded from pro key to controller. Press " \bar{C} " key to confirm downloading of parameter values from Pro key to controller.

Disclaimer: This manual & its contents remain the sole property of PVR CONTROLS . India and shall not be reproduced or distributed without authorization. Although great care has been taken in the preparation of this document, the company or its vendors in no event will be liable for direct, indirect, special, incidental or consequential damage arising out of the use or inability to use the product or documentation, even if advised of the possibility of such damages. No part of this manual may be reproduced or transmitted in any form or by any means without the prior written permission of the company. PVR CONTROLS ., reserves the right to make and changes or improvements without prior notice.

Warranty: This product is warranted against defects in materials and workmanship for a period of one year from the date of purchase. During the warranty period, product determined by us to be defective in form or function will be repaired or, at our option, replaced at no charge. This warranty does not apply if the product has been damaged by accident, abuse, and misuse or as a result of service or modification other than by the company. This warranty is in lieu of any other warranty expressed or implied. In no event shall the company be held liable for incidental or consequential damages, including lost revenue or lost business opportunity arising from the purchase of this product.

OUR OTHER PRODUCTS

Precision Control, always

Digital Panel Meter
Power Analyzer
Timer , PLC , HMI
Data Logger

02 / 03.03.2020

Calibration Certificate

DATE	
MODEL NO.	
CONTROLLER SR. NO.	

Claimed Accuracy :
 For TC inputs : 0.3% of FS
 For RTD inputs : 0.1% of FS +/-1 $^{\circ}\text{C}$
 (20 min of settling time for TC inputs)

Calibration Instrument & Sr. No :

Calibrated ON : _____
 Valid Upto : _____

The calibration of this unit has been verified at the following values :

SENSOR TYPE	VALUE TESTED ($^{\circ}\text{C}$)	VALUE Observed ($^{\circ}\text{C}$)
RTD	0°C	All values within specified limit of accuracy
	100°C	
	350°C	
J,K	50°C	
	400°C	
	650°C	

Instrument is confirmed accepted as accuracy is within the specified limit. This certificate is valid upto one year from the date of issue.

Checked By :

(Specification are subject to change, since development is a continuous process.)

PVR Controls, India

Ordering Information

